

Product Name: ZX050-BYP Passive SMA Splitter breakout adapter

Product Description: Passive SMA splitter Breakout Adapter enabling characterization, functional testing, using 50 Ω (Ohms) 35μ gold plated SMA connectors as access point. Designed in 4 layer PCBoard with improved signal integrity and crosstalk.

Ideal evaluation, bringup, and testing applications.

Available GND test point for ease of accessing inner GND layers along with top and bottom GND fills.

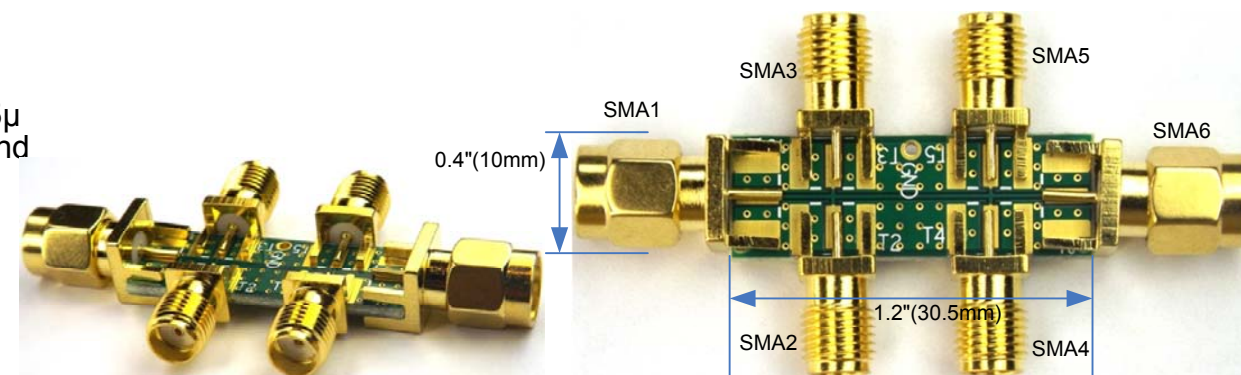

ZX050-BYP-PJJJP

Application: Bringup, Characterization, testing, development, modular design evaluations

Target Application : Designed specifically as passive SMA splitter without any on-board discrete

Headers: Ground access test point (GND) - 0.025" SQ with 0.32" (5.6mm) post height

SMA:

- Impedance: 50Ω
- Temp Range: -65°C +165°C
- Vibration: MIL-STD-202, Method 213
- Frequency Range: DC – 12GHz
- Working Voltage: 335V max
- Withstand Voltage: 1000V rms
- Center Contact: ≤3mΩ
- Outer Contact: ≤2mΩ
- Insulation resistance: ≥5000MΩ
- VSWR Straight: ≤1.15 (0.8-2.5G)

Simplified Block Diagram:

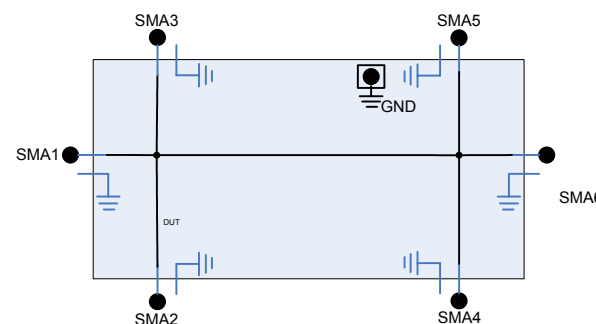

Ordering INFO:

| | SMA | | | | | |
|-------------|-----|---|---|---|---|---|
| Part Number | 1 | 2 | 3 | 4 | 5 | 6 |
| ZX050-BYP- | J | J | J | J | J | J |
| ZX050-BYP- | P | J | J | J | J | P |
| ZX050-BYP- | X | X | X | X | X | X |

-XXXXXX orders, please specify the required SMA type connectors when ordering as "the instructor" or "Note"

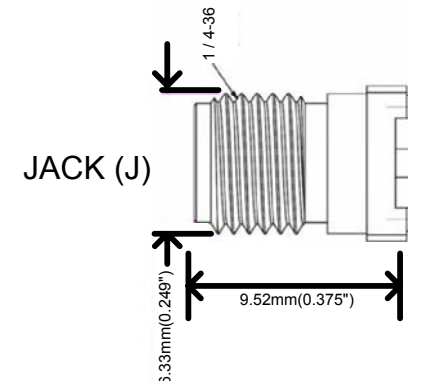
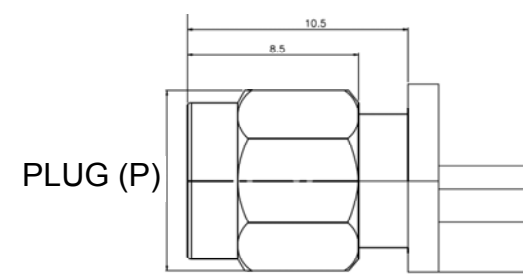

Note
ALL ZEBAX products are RoHS compliant and Lead Free unless otherwise indicated.

| | | |
|---|------------------|-------------------------------------|
| ZEBAX TECHNOLOGIES SANTA CRUZ, CA U.S.A (831) 2 2 2 - 0717 WWW.ZEBAX.COM | | |
| SPECIFIED DIMENSIONS ARE INCHES (MM). ROHS COMPLIANT | | ASSEMBLY DRAWING ITEM: ZX050-BYP |
| DESCRIPTION: Passive SMA Splitter breakout adapter | | |
| CHECKED: M. MARINA | DRAWN: SLAVIK | REVISION: 1.0 SHEET: 1 OF 1 |

Notice

ALL ZEBAX TECHNOLOGIES DESIGN SPECIFICATIONS, DRAWINGS, PUBLICATIONS, AND OTHER DOCUMENTS (TOGETHER AND SEPARATELY, "MATERIALS") ARE BEING PROVIDED "AS IS." ZEBAX MAKES NO WARRANTIES, EXPRESSED, IMPLIED, STATUTORY, OR OTHERWISE WITH RESPECT TO THE MATERIALS, AND EXPRESSLY DISCLAIMS ALL IMPLIED WARRANTIES OF NO INFRINGEMENT, MERCHANTABILITY, AND FITNESS FOR A PARTICULAR PURPOSE.

Information furnished is believed to be accurate and reliable. However, Zebax Technologies assumes no responsibility for the consequences of use of such information or for any infringement of patents or other rights of third parties that may result from its use. Specifications mentioned in this publication are subject to change without notice. This publication replaces all other information previously supplied. Zebax Technologies products are not authorized as in life support devices or systems.